



Cambridge IGCSE™

CANDIDATE
NAME

--

CENTRE
NUMBER

--	--	--	--	--

CANDIDATE
NUMBER

--	--	--	--



CAMBRIDGE INTERNATIONAL MATHEMATICS

0607/41

Paper 4 (Extended)

October/November 2020

2 hours 15 minutes

You must answer on the question paper.

You will need: Geometrical instruments

INSTRUCTIONS

- Answer **all** questions.
- Use a black or dark blue pen. You may use an HB pencil for any diagrams or graphs.
- Write your name, centre number and candidate number in the boxes at the top of the page.
- Write your answer to each question in the space provided.
- Do **not** use an erasable pen or correction fluid.
- Do **not** write on any bar codes.
- You should use a graphic display calculator where appropriate.
- You may use tracing paper.
- You must show all necessary working clearly and you will be given marks for correct methods, including sketches, even if your answer is incorrect.
- Give non-exact numerical answers correct to 3 significant figures, or 1 decimal place for angles in degrees, unless a different level of accuracy is specified in the question.
- For π , use your calculator value.

INFORMATION

- The total mark for this paper is 120.
- The number of marks for each question or part question is shown in brackets [].

This document has **20** pages. Blank pages are indicated.

Formula List

For the equation $ax^2 + bx + c = 0$ $x = \frac{-b \pm \sqrt{b^2 - 4ac}}{2a}$

Curved surface area, A , of cylinder of radius r , height h . $A = 2\pi rh$

Curved surface area, A , of cone of radius r , sloping edge l . $A = \pi rl$

Curved surface area, A , of sphere of radius r . $A = 4\pi r^2$

Volume, V , of pyramid, base area A , height h . $V = \frac{1}{3}Ah$

Volume, V , of cylinder of radius r , height h . $V = \pi r^2 h$

Volume, V , of cone of radius r , height h . $V = \frac{1}{3}\pi r^2 h$

Volume, V , of sphere of radius r . $V = \frac{4}{3}\pi r^3$



$$\frac{a}{\sin A} = \frac{b}{\sin B} = \frac{c}{\sin C}$$

$$a^2 = b^2 + c^2 - 2bc \cos A$$

$$\text{Area} = \frac{1}{2}bc \sin A$$

Answer **all** the questions.

- 1 Ten students at a school each study chemistry and physics. Their marks in an examination in each subject are recorded.

Chemistry mark (x)	27	36	48	52	53	62	75	80	86	93
Physics mark (y)	45	68	36	55	62	73	66	81	94	80

- (a) What type of correlation is there between the chemistry mark and the physics mark?

..... [1]

- (b) Find

- (i) the mean chemistry mark,

..... [1]

- (ii) the mean physics mark.

..... [1]

- (c) (i) Find the equation of the regression line for y in terms of x .

$y =$ [2]

- (ii) Another student scored 40 in the chemistry examination but was absent for the physics examination.

Estimate a physics mark for this student.

..... [1]

2 (a) Write the number 25.0467

(i) correct to 1 decimal place,

..... [1]

(ii) correct to 3 significant figures,

..... [1]

(iii) correct to the nearest 10,

..... [1]

(iv) correct to the nearest 0.001,

..... [1]

(v) in standard form.

..... [1]

(b) Change

(i) 20 cm into metres,

..... m [1]

(ii) 20m^2 into square centimetres,

..... cm^2 [1]

(iii) 18 km/h into metres per second.

.....m/s [2]

- 3 (a) Solve the simultaneous equations.
You must show all your working.

$$2x + 5y = -12$$

$$7x - 3y = -1$$

$$x = \dots\dots\dots$$

$$y = \dots\dots\dots [4]$$

- (b) Solve $(4x - 1)(2x + 3) = -5$.
You must show all your working.

$$x = \dots\dots\dots \text{ or } x = \dots\dots\dots [5]$$

4 (a)

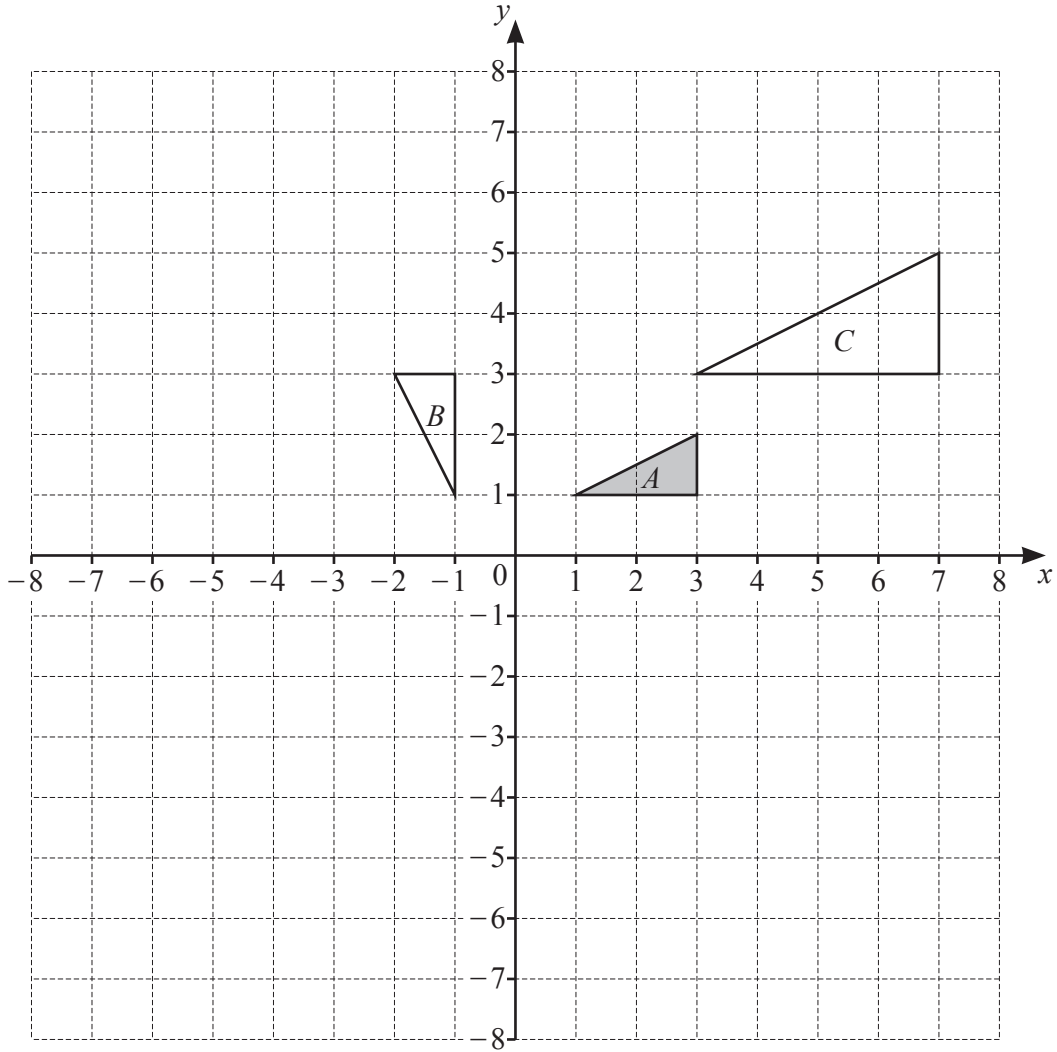

- (i) Describe fully the **single** transformation that maps triangle *A* onto triangle *B*.

 [3]
- (ii) Describe fully the **single** transformation that maps triangle *A* onto triangle *C*.

 [3]
- (iii) On the grid, draw the stretch of triangle *A*, scale factor 2, *y*-axis invariant. [2]

(b) Describe fully the **single** transformation that is the **inverse** of

(i) a reflection in $y = 2$,

.....

..... [1]

(ii) a translation with vector $\begin{pmatrix} -5 \\ 2 \end{pmatrix}$.

.....

..... [2]

5

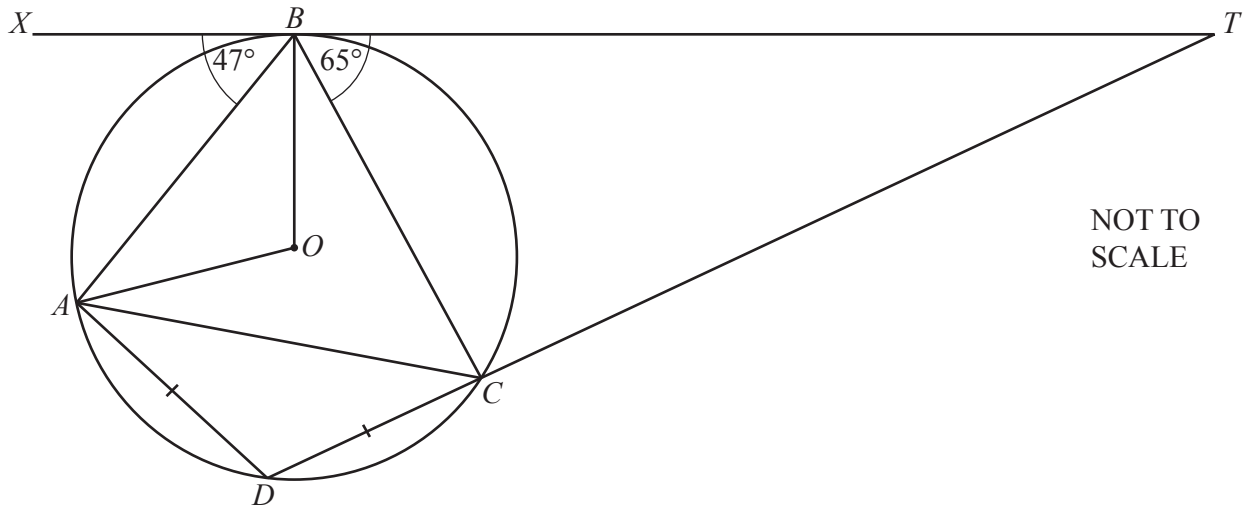

A , B , C and D lie on a circle, centre O .
 $AD = CD$ and XBT is a tangent to the circle at B .
 TCD is a straight line.
 Angle $XBA = 47^\circ$ and angle $TBC = 65^\circ$.

Find the value of

(a) angle OBX ,

Angle $OBX = \dots\dots\dots$ [1]

(b) angle AOB ,

Angle $AOB = \dots\dots\dots$ [2]

(c) angle CAO ,

Angle $CAO = \dots\dots\dots$ [2]

(d) angle CDA ,

Angle $CDA = \dots\dots\dots$ [2]

(e) angle DAC ,

Angle $DAC = \dots\dots\dots$ [2]

(f) angle CTB .

Angle $CTB = \dots\dots\dots$ [2]

6 Find the next term and the n th term in each of these sequences.

(a) 125, 64, 27, 8, 1, ...

Next term

n th term [3]

(b) 6, 12, 20, 30, 42, ...

Next term

n th term [4]

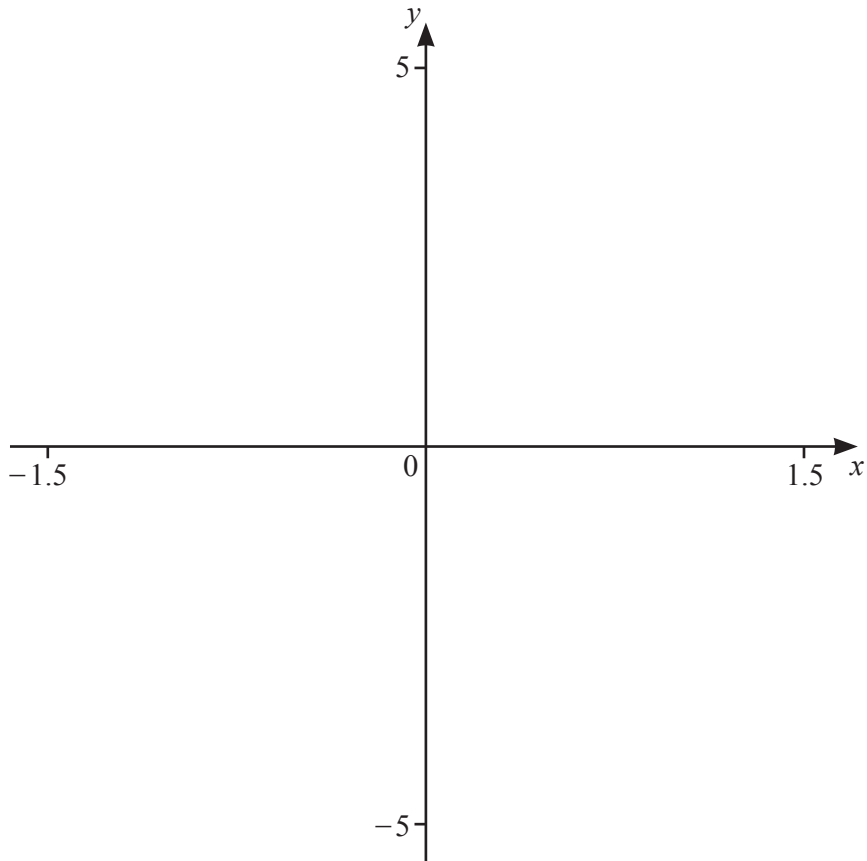

$$f(x) = \left| x^3 - \frac{1}{x} \right|$$

(a) On the diagram, sketch the graph of $y = f(x)$, for values of x between -1.5 and 1.5 . [3]

(b) Write down the equation of the asymptote of the graph.

..... [1]

(c) Solve the equation $f(x) = 2$ for values of x between -1.5 and 0 .

$x = \dots\dots\dots$ or $x = \dots\dots\dots$ [2]

(d) Solve the inequality $f(x) + x^2 \leq 2$ for values of x between -1.5 and 1.5 .

..... [3]

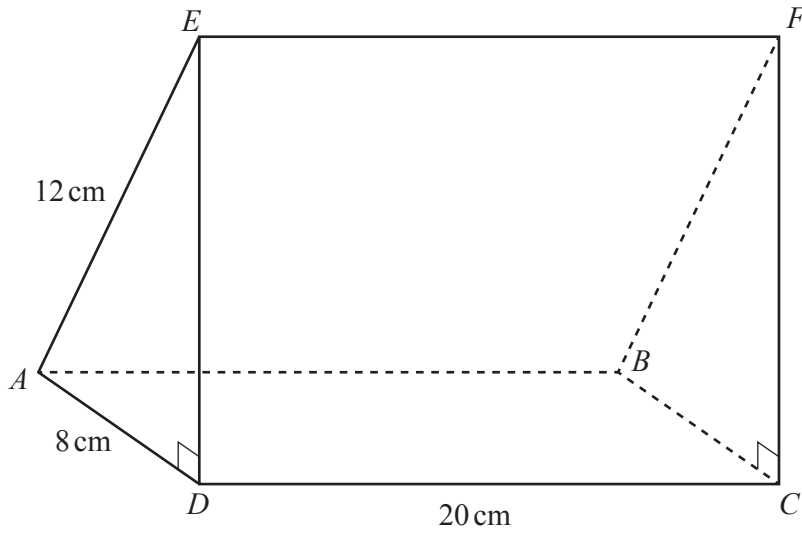

NOT TO SCALE

ABCDEF is a triangular prism.
ABCD is a rectangle.

Find

(a) *AC*,

AC =cm [2]

(b) *ED*,

ED =cm [2]

(c) angle EAD ,

Angle EAD = [2]

(d) angle FAC .

Angle FAC = [2]

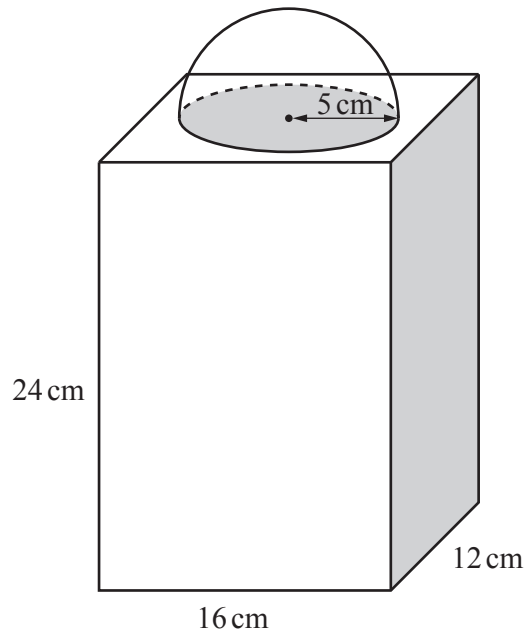

NOT TO
SCALE

The diagram shows a solid made from a cuboid and a solid hemisphere.
The cuboid measures 12 cm by 16 cm by 24 cm.
The hemisphere has radius 5 cm.

(a) Find

(i) the volume of the solid,

..... cm^3 [3]

(ii) the volume of a similar solid where the radius of the hemisphere is 3 cm.

..... cm^3 [2]

(b) Find

(i) the total surface area of the original solid,

..... cm^2 [3]

(ii) the total surface area of a similar solid where the radius of the hemisphere is 6 cm.

..... cm^2 [2]

10

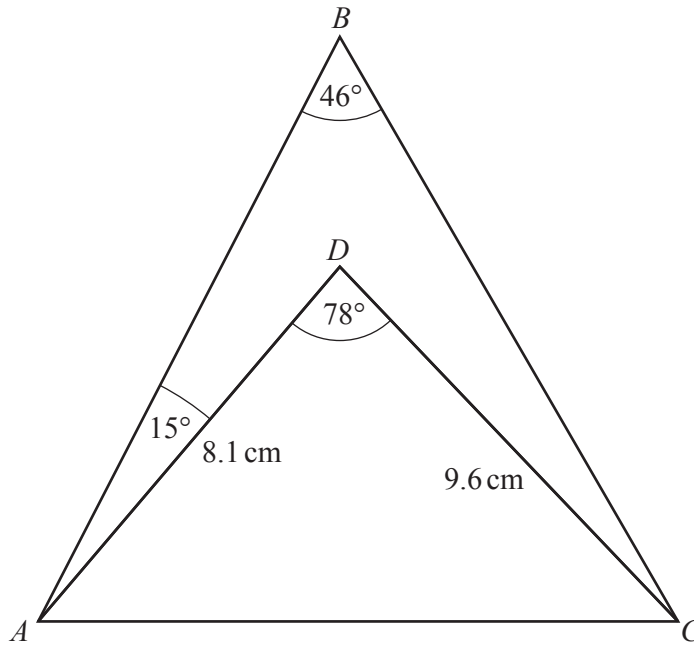
NOT TO
SCALE

ABC and ADC are triangles.

$AD = 8.1$ cm and $CD = 9.6$ cm.

Angle $ABC = 46^\circ$, angle $ADC = 78^\circ$ and angle $BAD = 15^\circ$.

(a) Find AC .

$AC = \dots\dots\dots$ cm [3]

(b) Show that angle $DAC = 57^\circ$, correct to the nearest degree.

[3]

(c) Find BC .

$BC = \dots\dots\dots\text{cm}$ [3]

(d) Find the area of quadrilateral $ABCD$.

$\dots\dots\dots\text{cm}^2$ [4]

11 A bag contains 4 red balls, 5 black balls and 3 white balls only.

(a) In an experiment, one ball is chosen at random.

(i) Find the probability that the ball chosen is **not** black.

..... [1]

(ii) This experiment is carried out 1440 times.

Find the expected number of times the ball chosen is not black.

..... [1]

(b) In a different experiment, one ball is chosen at random, the colour is noted, and the ball is replaced in the bag.

Another ball is then chosen at random and the colour is noted.

Find the probability that the balls chosen are

(i) both white,

..... [2]

(ii) both the same colour,

..... [3]

(iii) different colours.

..... [1]

(c) In another experiment, three balls are chosen at random without replacement.

(i) Find the probability that the first ball is **not** black, the second ball is black and the third ball is white.

..... [3]

(ii) Find the probability that exactly two of the balls are red.

..... [4]

Question 12 is printed on the next page.

12 Solve the equations.

(a) $6 - \frac{2}{x} = -2$

$x = \dots\dots\dots$ [3]

(b) $3 + 2(4x + 5) = 1 - 2(x + 8)$

$x = \dots\dots\dots$ [3]

(c) $3 \log x + 2 \log 3 = 2 \log 6 + \log 2$

$x = \dots\dots\dots$ [3]

(d) $2^x = 10$

$x = \dots\dots\dots$ [3]

Permission to reproduce items where third-party owned material protected by copyright is included has been sought and cleared where possible. Every reasonable effort has been made by the publisher (UCLES) to trace copyright holders, but if any items requiring clearance have unwittingly been included, the publisher will be pleased to make amends at the earliest possible opportunity.

To avoid the issue of disclosure of answer-related information to candidates, all copyright acknowledgements are reproduced online in the Cambridge Assessment International Education Copyright Acknowledgements Booklet. This is produced for each series of examinations and is freely available to download at www.cambridgeinternational.org after the live examination series.

Cambridge Assessment International Education is part of the Cambridge Assessment Group. Cambridge Assessment is the brand name of the University of Cambridge Local Examinations Syndicate (UCLES), which itself is a department of the University of Cambridge.